

MADE  
IN THE **USA**

# HEATLESS REGENERATIVE DESICCANT DRYERS

---



**NORTEC**

Compressed Air & Gas Dryers

[nbdry.com](http://nbdry.com)

# Principle Of Dessicant Operation

Nortec's twin tower design allows for continuous adsorption of water vapor from compressed air by using our X-PACK – a hygroscopic desiccant with high crush strength and a high surface/volume ratio.

Drying is accomplished by passing compressed air through one desiccant bed adsorbing moisture while the other is being simultaneously regenerated with the expanded purge air.

Regeneration of desiccant is accomplished without the use of heat. The wet bed is dried by diverting a small portion of the super-dry air from the outlet at near atmospheric pressure. The purge flow rate is adjustable to suit the specific outlet conditions (desired dewpoint). The super dry air flows in a counter direction through the wet bed, sweeping all the water vapor previously adsorbed by the desiccant. The microprocessor controller monitors the automatic operation of the dryer and provides options for load management, fixed cycle and dewpoint-based control.

Nortec ensures pressure equalization in the twin towers prior to switching. This prevents line surge and minimizes desiccant attrition. The tower being reactivated will be gradually re-pressurized at the end of its reactivation cycle before switchover takes place. Purge flow and de-pressurization are in downward direction, counter flow to the drying air flow.

# Why dry air?

In today's industrial world, compressed air is considered the fourth utility. And to be used in industrial processes, air must be cleaned. Atmospheric air contains contaminants—dust particles, water vapor, oil, and other impurities. As air is compressed, these contaminants become more concentrated, causing a variety of problems—equipment wear, increased maintenance, lower production efficiency, pipe and line corrosion, and other expensive headaches.

In some industries, even the smallest contaminants in compressed air can cause production problems or errors that cost thousands of dollars to correct. So dry air is absolutely critical in a modern factory.

Nortec is dedicated to creating the systems needed to dry air so that your production is maximized and your costs are dramatically reduced.

**It's Dry Air. Reimagined.**

Dryer Operation	
1	Coalescing Pre-Filter
2	Pre-Filter Electronic Drain Valve
3	Inlet Valves N/O
4	Angle Body Purge Exhaust Valve
5	Purge Pilot Valve
6	Desiccant Drain Port
7	Stainless Steel Diffuser
8	Pressure Vessels
9	Pressure Gauge
10	Pressure Relief Valve
11	Control Air Filter
12	Control Air Tubing (1/4")
13	Purge Exhaust Mufflers
14	Outlet Check Valve
15	Purge Adjustment Valve
16	After Filter Particulate Type
17	Internal Float Drain
18	Pressure Differential Indicator
19	Desiccant Fill Port
20	Inlet Pilot Valve 4-Way-2Pos
21	Check Valve
22	Dew Point Transmitter
23	Sample Air Valve and Coil

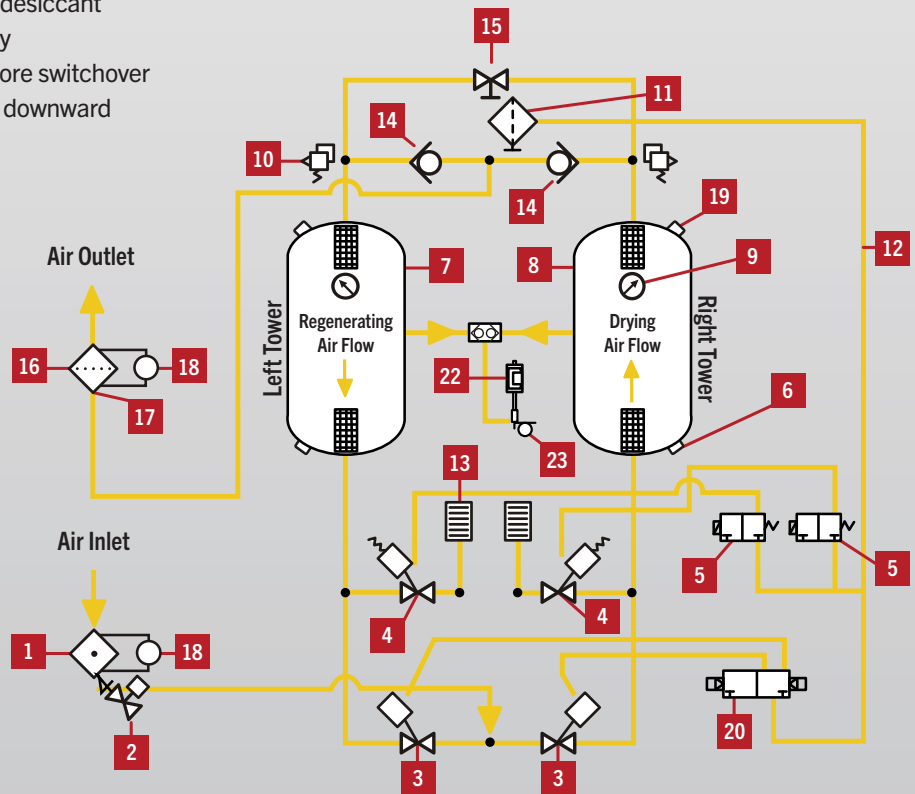

## EXCEPTIONAL ENGINEERING SUPPORT AND EXPERIENCE

Nortec's engineers and experts have been working with dry air systems and chillers for more than three decades. We know how to design and build air/gas dryers and chillers. We've built Refrigerant Systems as large as 20,000 CFM. Desiccant Systems as large as 16,000 CFM. Gas Systems as large as 20,000 CFM. Nortec has remarkable expertise ready to go to work for you.

# THE NORTEC HEATLES

## Premium Parts



### PLC with HMI Controllers Provide the Information You Need

- iOS and Android WindEDIT App
- Bluetooth communication
- Embedded Ethernet port
- Embedded SD memory port
- Modbus TCP and RTU
- Embedded RS232C/RS485 user selectable
- Maximum 520 digital I/O
- Maximum 126 analog I/O
- Data logging
- Web Server Functions
- Large programming and data memory
- SAE J1939 CPU
- -25° to 65° C operating temperature



### Digital Dewpoint Transmitter

The digital dewpoint transmitters are compact, reliable and continuously monitor the dryer performance. With available options, monitors can be used as indicators, alarm units or as controllers. A simple interface permits the operator to choose between multiple units, output the data to a PC, set alarm levels and do field setpoint.



### Quality Desiccant Media

Nortec uses a mixture of adsorption media in its heatless range of desiccant dryers to achieve consistent dewpoint (Made in the USA). Activated Alumina, Molecular Sieve and Silica Gel are used in varying ratios depending on the application. The long lasting, high crush strength media has a very high surface/volume ratio.



**MADE**  
IN THE **USA**



# S DESICCANT DRYER



## Butterfly Valve (800 cfm and up)

These versatile, high-performance butterfly valves are used by Nortec to provide you with precision control and complete bubble-tight shut off. The digitally controlled actuators provide easy PLC interface and feature fast response time. The tongue-and-groove seat design feature ensures complete isolation of flowing media from the body and stem. Rugged and reliable, these valves are designed to provide years of trouble-free service.



## State-of-the-Art Check Valve

High-temperature, wafer- combination swing check valves are flow activated. The elliptical shape of the inlet port accelerates the inlet media through the valve. The disc's angle and shape allows the air to travel faster around the disc, thus creating lift like an aircraft wing, and opens the valve in full position even at low flow rate.



## Angle Body Piston Valve (80 - 600 S.C.F.M)

These high-performance, 2-way direct acting valves are designed for reliability and durability. It uses a profiled disc in conjunction with a high-resolution compact positioner and linear feedback potentiometer to provide precise proportional flow. The stainless steel internals and a tough fiber composite actuator body, along with the use of oversized bearing and Viton® seals, make it possible to consistently provide smooth piston movement for years of trouble-free service.

# PERFORMANCE ADVANTAGE

## HDD Series Specifications

Model	Inlet Flow Capacity @100 PSIG CFM	Inlet/Outlet Connections	Dimensions L x W x H	Weight (lbs)	Model Pre Filter	Model After Filter
40-HDD	40	.50" NPT	30x24x39	300	NCF-60	NPF-60
60-HDD	60	.75" NPT	30x24x39	360	NCF-90	NPF-90
80-HDD	80	.75" NPT	34x24x76	550	NCF-90	NPF-90
100-HDD	100	1" NPT	34x24x76	690	NCF-150	NPF-150
125-HDD	125	1" NPT	34x24x76	710	NCF-150	NPF-150
150-HDD	150	1" NPT	40x36x76	810	NCF-200	NPF-200
200-HDD	200	1" NPT	40x36x83	850	NCF-200	NPF-200
250-HDD	250	1.5" NPT	44x40x83	1010	NCF-300	NPF-300
300-HDD	300	1.5" NPT	44x40x85	1200	NCF-300	NPF-300
400-HDD	375	.50" NPT	46x42x85	1350	NCF-500	NPF-500
500-HDD	500	2" NPT	50x45x90	1460	NCF-500	NPF-500
650-HDD	650	2" NPT	50x45x90	1790	NCF-700	NPF-700
800-HDD	800	3" FLG	55x48x105	2150	NCF-1300	NPF-1300
1000-HDD	1000	3" FLG	55x48x105	2960	NCF-1300	NPF-1300
1250-HDD	1250	3" FLG	60x50x109	3470	NCF-1300	NPF-1300
1500-HDD	1500	3" FLG	60x50x109	4180	NCF-1600	NPF-1600
2000-HDD	2000	3" FLG	70x62x115	4980	NCF-2500	NPF-2500
2500-HDD	2500	4" FLG	70x62x115	5800	NCF-2500	NPF-2500
3000-HDD	3000	4" FLG	80x70x120	6400	NCF-3000	NPF-3000
4000-HDD	4000	6" FLG	90x80x122	9100	NCF-5000	NPF-5000
5000-HDD	5000	6" FLG	98x86x120	11800	NCF-5000	NPF-5000

## HDD Series Cont.

### Maximum Working Pressure

150 PSIG (10 BARG) standard  
250 PSIG (17.3 BARG) optional

### Minimum Working Pressure

50 PSIG (For pressure less than 50 PSIG contact factory.)

### Maximum Inlet Temperature

1200° F (490° C) (Dewpoint will rise at 1200° F inlet temperature.)

### Minimum Ambient Temperature

340° F (1.60° C) standard / -150° F (-260° C) with optional low ambient package.

### Voltage

120 V-1-60 HZ or 208 V-1-60 H

All Information Subject to Change without notice.

### Correction Factor for Inlet Air Pressure

Inlet Pressure	PSIG	50	60	70	80	90	100	110	120	130	140	150	175	200	225	250
	BARG	3.5	4.1	4.8	5.5	6.2	6.9	7.6	8.3	9.0	9.7	10.3	12.1	13.8	15.5	17.3
Factor F1		0.56	0.65	0.74	0.83	0.91	1.00	1.04	1.08	1.12	1.16	1.20	1.29	1.37	1.45	1.52

### Correction Factor for Inlet Air Temperature

°F	70	80	90	100	105	110	115	120
°C	21	27	32	38	40	43	45	49
Factor F2	1.12	1.01	1.06	1	0.93	0.86	0.80	0.75

### How To Find Air Flow Capacity:

**Air flow capacity = Nominal capacity of dryer x Factor F1 x Factor F2**

Example: A 500-BPD has a nominal capacity of 500 SCFM. What is the maximum allowable flow through the dryer at following operating conditions?

Air Inlet Pressure: 110 PSIG (7.6 BARG) **F1 = 1.04**

Air Inlet Temperature: 105° F (40.50° C) **F2 = 0.93**

Air flow capacity = **500 x F1 x F2**

Air flow capacity = **500 x 1.04 x 0.93 = 483.6 SCFM**

**This is the maximum air flow rate that dryer can accept under those operating conditions.**

### How To Select a Suitable Dryer For Given Capacity:

**Minimum Std. Air Flow = Design Air Flow / Factor F1 / Factor F2**

Example: Given the operating parameters below, find a suitable dryer.

Design Flow Rate: 950 SCFM

Inlet Air Pressure: 110 PSIG

Inlet Air Temperature: 105° F

**F1 = 1.04**

**F2 = 0.93**

Minimum Std. Air Flow = **950/1.04/0.93 = 982.22**

**Therefore the model suitable for the conditions above is 1000-BPD.**

# HEATLESS DESICCANT DRYER

## Standard Features

---

The performance of any desiccant dryer depends on the quality of its key components. Nortec uses the best available valves, controllers and desiccant. With accurately designed and sized components, the dryers are manufactured to provide you with years of trouble free operation.

- On/Off switch
- PLC with HMI controls with 4.3 operating interface
- Completely automatic operation
- User step mode for emergencies
- UL/CUL certified electrical
- NEMA 4 electrical enclosure
- Non-lubricated inlet valve
- High-efficiency stainless steel body piston valve (80 - 600 cfm)
- Spring load check valve
- Field adjustable timer cycle, 6, 10, or 15 minutes
- Stainless steel inlet/outlet diffusers
- ASME and CRN code construction and stamped pressure vessel
- Structural steel frame with floor stand
- Full charge of desiccant up to 1500 S.C.F.M
- Pre-piped and mounted pre-filter and after filter
- Safety pressure relief valve for each tank
- Fail safe design in case of power failure

## Optional Features

---

- ⊕ Pneumatic control timer. Eliminates need for control electric power
- ⊕ NEMA 4x and explosion proof NEMA 7
- ⊕ High pressure up to 10,000 PSIG
- ⊕ Energy saver demand cycle control
- ⊕ Optimal voltage (220/230/1/50-60HZ)
- ⊕ High dew point alarm
- ⊕ Switching failure alarm
- ⊕ -100° F pressure dew point
- ⊕ Special finishes for severe environments, process industries, offshore drilling rigs, etc.



# High Pressure Series Dryers

This dryer is used to remove moisture from compressed air for industrial use. Typically, the dryer is used for drying compressed air from a high pressure compressor station.

During pre-treatment of the compressed air, by means of separators and fine filters, only the liquid water components can be removed from the compressed air. After pre-treatment the dryer also removes the vaporous water components. The compressed air is dried until only a very low residual concentration of water vapour remains. This residual moisture content is measured as the pressure dew point in °C/F.

The dryer works completely automatically and is designed for continuous operation. Thanks to numerous communication interfaces and an optional moisture measuring system the dryer can be operated very economically. The high pressure series dryers can be used throughout the industry, especially where the air/gas needs to be dry at high pressure (up to 10,000 PSIG) and pressure dew point (-40°F to -100°F).

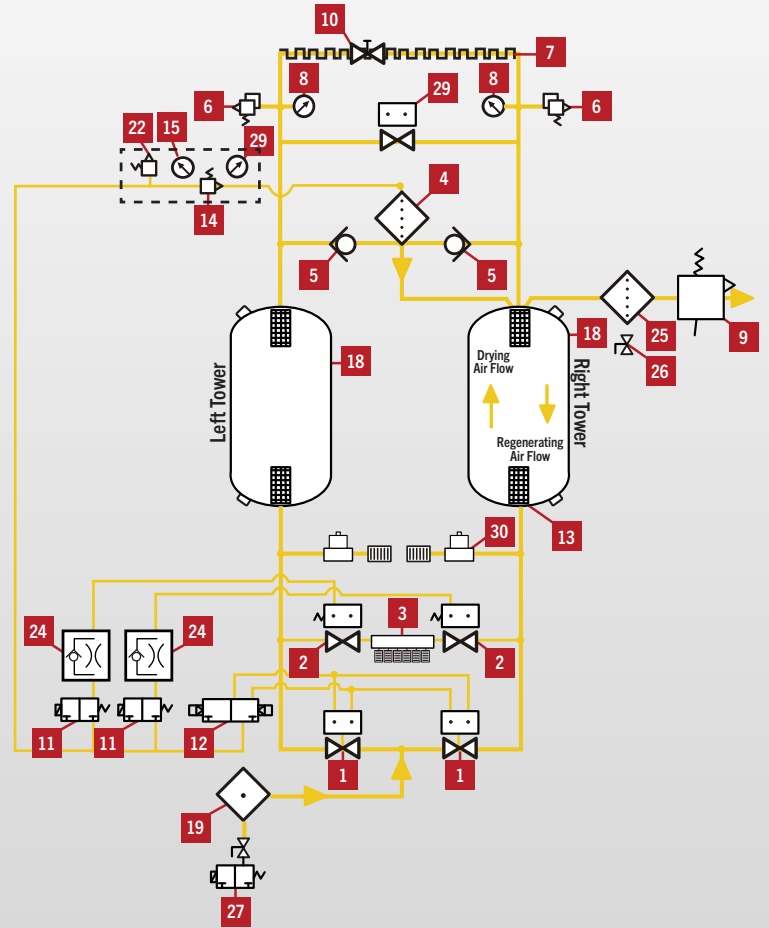

## Dryer Operation

- 1 Inlet Valve
- 2 Purge Exhaust Valve
- 3 Purge Exhaust Manifold
- 4 Control Air Filter
- 5 Purge Check Valve
- 6 Pressure Relief Valve
- 7 Purge Heater
- 8 Tower Pressure Gauge
- 9 Back Pressure Gauge
- 10 Purge Adjustment Valve
- 11 Purge Exhaust Pilot Solenoid Valve
- 12 Tower Selector Valve
- 13 Stainless Steel Diffuser
- 14 Control Air Pressure Regulator
- 15 Control Air Pressure Gauge (Low Pressure Side)
- 16 Dryer Controller
- 17 Electrical Enclosure (Not Shown)
- 18 Desiccant Tower
- 19 Coalescer Pre-Filter
- 20 Particulate Outlet After Filter
- 21 Coalescer Automatic Timed Solenoid Drain Valve
- 22 Control Air Pressure Relief Valve (Set 150PSIG)
- 23 Control Air Pressure Regulator High Pressure Gauge
- 24 Purge Exhaust Flow Control Valve for Slow Depressurization
- 25 Particulate Afterfilter Drain / Vent Drain
- 26 Manual Valve
- 27 Timer Drain
- 28 Particulate Strainer
- 29 Re-Pressurization Valve
- 28 De-Pressurization Solenoid Valve
- 29 Purge Exhaust Mufflers

## High Pressure Regenerative Compressed Air Dryers

Model	Capacity (SCFM)	Connection (NPT)	Pressure (PSIG)	Dimensions in Inches			Weight (LBS)
				L	W	H	
HPD - 100	100	1/4"	1500	26	20	40	200
HPD - 250	250	1/2"	1500	30	26	50	220
HPD - 350	350	1/2"	1500	45	30	60	220
HPD - 500	500	3/4"	1500	50	36	69	250
HPD - 100	100	1/4"	3600	26	20	40	250
HPD - 250	250	1/4"	3600	30	26	50	250
HPD - 350	350	1/2"	3600	45	30	60	350
HPD - 500	500	1/2"	3600	50	36	69	350
HPD - 100	100	1/4"	5000	26	20	40	400
HPD - 250	250	1/4"	5000	30	26	50	400
HPD - 350	350	1/2"	5000	45	30	60	450
HPD - 500	500	1/2"	5000	50	36	69	450



# High Pressure Series Dryers

The High Pressure Series Dryer is designed to remove moisture from compressed air for industrial use.

Applications include:

- Natural Gas Filling Stations
- Power Stations and Substations
- Breathing Air Generation
- Aerospace
- Molding
- Marine

## DRY AIR REIMAGINED

Nortec was founded in 2008 based on three key Pillars of Performance:

1. **Quality** - Quality is the foremost goal in all our products. We specifically design our products to provide exceptional performance and to stand the test of time—a must for every industry.
2. **Service** - Our goal is perfection, supporting every customer in any area that is needed.
3. **Innovation and Design** - We push ourselves to be the best with current industry expectations and continuously improve to create better processes and products.



Regenerative Desiccant Compressed Air Dryers



Refrigerated Compressed Air Dryers



Industrial Process Chillers (5-500 Ton)



Gas Dryers



Aftercoolers & Separators



Closed Loop Fluid Cooler & Pumping Station

